

TECHNICAL DATA

Basic Execution

TYPE	STROKES /1"	MAX FLOW RATE l/h	MAX PRESSURE BAR				CONNECTIONS		
			0,09 kW OBL std		0,18 kW MU		THREADED		FLANGED
			A	P	A	P	6.F	UNI	ANSI
XR2.15	55	0,6	10	10	10	10	1/4" g.f. BSPF	DN 15	1/2"
XR2.15	72	0,9	10	10	10	10	1/4" g.f. BSPF	DN 15	1/2"
XR2.15	85	1,2	10	10	10	10	1/4" g.f. BSPF	DN 15	1/2"
XR2.15	111	1,5	10	10	10	10	1/4" g.f. BSPF	DN 15	1/2"
XR2.15	145	2	10	10	10	10	1/4" g.f. BSPF	DN 15	1/2"
XR2.30	28	1,8	20	10	20	10	1/4" g.f. BSPF	DN 15	1/2"
XR2.30	36	2,5	20	10	20	10	1/4" g.f. BSPF	DN 15	1/2"
XR2.30	55	3,8	20	10	20	10	1/4" g.f. BSPF	DN 15	1/2"
XR2.30	72	5	20	10	20	10	1/4" g.f. BSPF	DN 15	1/2"
XR2.30	85	5,5	20	10	20	10	1/4" g.f. BSPF	DN 15	1/2"
XR2.30	111	7,5	20	10	20	10	1/4" g.f. BSPF	DN 15	1/2"
XR2.30	145	11	20	10	20	10	1/4" g.f. BSPF	DN 15	1/2"
XR6.30	55	10	17	10	20	10	3/8" g.f. BSPF	DN 15	1/2"
XR6.30	72	14	17	10	20	10	3/8" g.f. BSPF	DN 15	1/2"
XR6.30	85	20	17	10	20	10	3/8" g.f. BSPF	DN 15	1/2"
XR6.30	111	23	17	10	20	10	3/8" g.f. BSPF	DN 15	1/2"
XR6.30	145	30	17	10	20	10	3/8" g.f. BSPF	DN 15	1/2"
XR6.38	72	26	10	10	15	10	3/8" g.f. BSPF	DN 15	1/2"
XR6.38	85	32	10	10	15	10	3/8" g.f. BSPF	DN 15	1/2"
XR6.38	111	42	10	10	15	10	3/8" g.f. BSPF	DN 15	1/2"
XR6.38	145	54	10	10	15	10	3/8" g.f. BSPF	DN 15	1/2"
XR6.38	170	65	10	10	15	10	3/8" g.f. BSPF	DN 15	1/2"
XR6.48	72	42	7	7	10	10	3/8" g.f. BSPF	DN 15	1/2"
XR6.48	85	50	7	7	10	10	3/8" g.f. BSPF	DN 15	1/2"
XR6.48	111	66	5	5	8	8	3/8" g.f. BSPF	DN 15	1/2"
XR6.48	145	87	5	5	8	8	3/8" g.f. BSPF	DN 15	1/2"
XR6.48	170	105	5	5	8	8	3/8" g.f. BSPF	DN 15	1/2"

* Flow rates valid also for single-phase motors M1 with half number of strokes.

For fluids with viscosity 1000÷2000 CpS 3-Phase and MU1 single-phase motors

TYPE	STROKES /1"	MAX FLOW RATE l/h	MAX PRESSURE BAR		CONNECTIONS		
			AISI	PVC	THREADED		FLANGED
					6.F	UNI	ANSI
XR6.30	19	3	20	10	1/4" g.f. BSPF	DN 15	1/2"
XR6.30	28	5	20	10	1/4" g.f. BSPF	DN 15	1/2"
XR6.38	19	7	15	10	3/8" g.f. BSPF	DN 15	1/2"
XR6.38	28	10	15	10	3/8" g.f. BSPF	DN 15	1/2"
XR6.38	36*	13	15	10	3/8" g.f. BSPF	DN 15	1/2"
XR6.48	28	17	8	8	3/8" g.f. BSPF	DN 15	1/2"
XR6.48	36*	21	8	8	3/8" g.f. BSPF	DN 15	1/2"

* Available also with single-phase motor M1.

MATERIALS OF CONSTRUCTION

PARTICOLARI	A	P	P11	A22
LIQUID END	AISI 316L	PVC	PVC	PVC
VALVE GUIDE	PE	PE	PE	PE
VALVE SEAT	AISI 316L	PVC	AISI 316L	INCOLOY 825
VALVE	AISI 316L	PIREX	AISI 316L	CARPENTER 20
VALVE SEAL	VITON (FPM)	VITON (FPM)	VITON (FPM)	VITON (FPM)
VALVE HOUSING	AISI 316L	PVC	PVC	PVC
DIAPHRAGM	TEFLON (PTFE)	TEFLON (PTFE)	TEFLON (PTFE)	TEFLON (PTFE)

BUILT-IN RELIEF VALVE SETTING WORKING PRESSURE

BUILT-IN RELIEF VALVE STD SETTINGS	MAX WORKING PRESSURE
5 bar	4 bar
7 bar	5,5 bar
8 bar	6,5 bar
10 bar	8 bar
15 bar	12 bar
17 bar	14,5 bar
20 bar	16 bar

Hydraulic Diaphragm Metering Pumps Spring Return

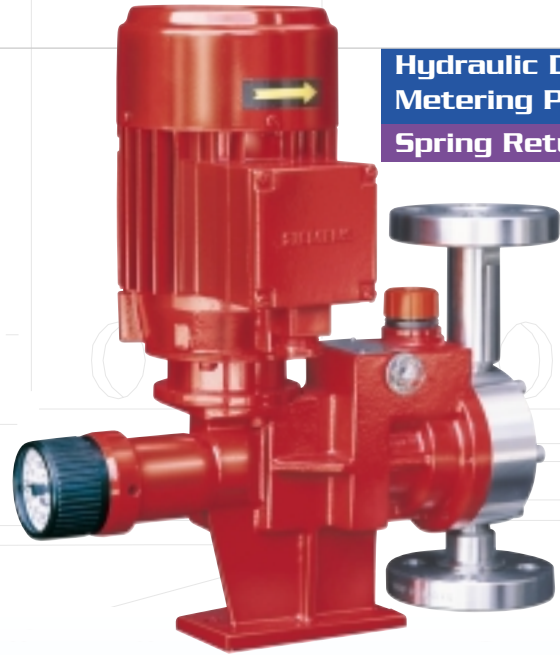

Diaphragm pump suitable for metering:

- Acids
- Bases
- Solvents with solid/slurries
- Medium viscosity fluids (up to 2,000 cps)
- High viscosity fluids (up to 22,000 cps)
- Foodstuff

- Flow Rate: Max flow rate 105 L/h.
- Motors: Eurotensione
- Pump: Single
- Material: Aluminium Casing
- Stroke: 2/6 mm.
- Weight: 15 Kg

MODEL NUMBER

KEY TO SYMBOLS	
PUMP TYPE	
PLUNGER STROKE: 2 - 6	
Ø PLUNGER: 15 - 30 - 38 - 48	
P	PVC VERSION
A	AISI-316L VERSION
P11	AISI-316L VALVES & SEATS
A22	SEAT: INCOLOY 825 - VALVES: CARPENTER 20
G	CLOCK-TYPE ADJUSTMENT
MU	UNIFED MOTOR
Z	4÷20 mA ELECTRIC ACTUATOR
W	3÷15 BAR PNEUMATIC ACTUATOR
F	UNI-ON FLANGED CONNECTIONS
FA	ANSI FLANGED CONNECTIONS
N°	STROKES/m: 19 - 28 - 36 - 55 - 72 - 85 - 111 - 145 - 170

XR 2. 30 P 85 F Z MU G

The XR pump design benefits from the technology developed for our MX series process hydraulic diaphragm pumps. Integral hydraulic diaphragm pump with built-in relief valve, air-bleed valve and mechanically actuated oil replenishing. The technical innovation lies in the combination of a process pump head of the MX series, with a spring return operating mechanism. The totally enclosed monobloc construction with no external moving parts and the built-in relief valve ensure full compliance with EC machine safety standard.

CONSTRUCTION CHARACTERISTICS

- 1 **BUILT-IN RELIEF VALVE**
Eliminates the cost, installation and maintenance of an external relief valve.
- 2 **HYDRAULIC SYSTEM**
In the mechanically actuated oil replenishing system the restored volume is determined by the diaphragm position at the limit of the suction stroke, which therefore controls the limit of delivery stroke deflection of the diaphragm caused by the plunger.
- 3 **CONNECTIONS**
Threaded BSPF. Flanged UNI/ANSI
- 4 **VALVES**
A wide range of materials (AISI 316L stainless steel, Pyrex, Ceramic, Hastelloy © C-276) is available to handle various liquids. Specially designed pump heads are available for liquids with viscosity up to 22,000 cps.
- 5 **DIAPHRAGM**
Pure PTFE with independent leak-free retention system allowing pump head maintenance without leakages.
- 6 **LIQUID END**
Machined from solid barstock.
- 7 **PUMP HEAD**
Drip groove to prevent corrosion of the pump casing.
- 8 **CRANK GEAR**
Supported in ball bearings, oil bath lubricated.
- 9 **PLUNGER**
No wearing parts; oil bath lubricated, sealess plunger. The small leakage via the plunger-cylinder clearance is restored by the hydraulic replenishment system at each stroke. No maintenance required.

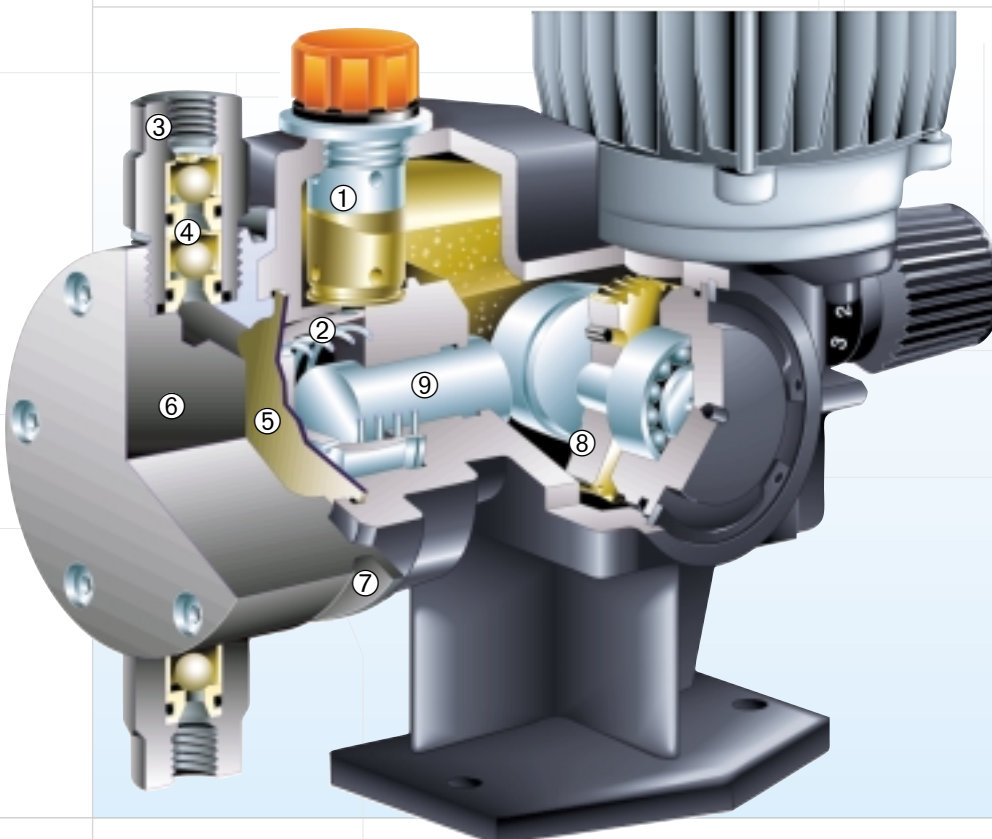

GENERAL FEATURES

- OBL "XR" series metering pumps are controlled-volume reciprocating pumps.
- The diaphragm operating mechanism, driven by a constant speed motor, is a spring-return cam. The stroke rate of the plunger is determined by the oil-bathed worm reduction gear. The discharge stroke is given by direct contact of the cam with the plunger, while the suction stroke is effected by the return spring.
- 0÷100 flow rate adjustment is achieved by limiting the return stroke of the plunger by means of a threaded stop with micrometer adjustment.
- The aluminium monobloc construction offers the advantage of a hydraulic system in a compact and economical design with few components.

MOTORS

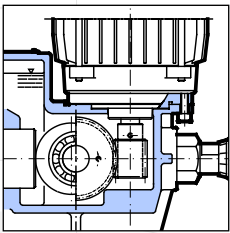
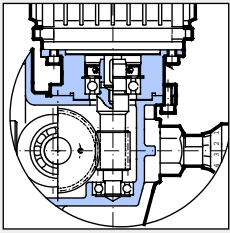
VERSIONS	TIPO	CODE	FASE	SIZE	FORMA	CARATTERISTICHE
Motor "BASIC" version 	STD MOTORS (SPECIAL LAFERT)	/	THREE-PH	56	*	TEFC 0,09 kW 4 POLES 230/400 V 50/60 Hz IEC 38
		M1	SINGLE-PH	56	*	TEFC 0,13 kW 2 POLES 230 V 50 Hz
Motor "UNEL-MEC" version 	IEC MOTORS	MU	THREE-PH	63	B14	TEFC 0,18 kW 4 POLES 230/400 V 50/60 Hz IEC 38
		MU1	SINGLE-PH	63	B14	TEFC 0,18 kW 4 POLES 230 V 50 Hz

* Special shaft and driving end.

OVERALL DIMENSIONS

ADVANTAGES

- The hydraulic system with its mechanically actuated oil replenishing (smart diaphragm) system overcomes many common suction and discharge problems.
- Maintenance is reduced to a minimum. The plunger operates in an oil bath, without packing, and maintains as-new volumetric efficiency even after 40,000 working hours. The diaphragm protected by the built-in relief valve and mechanically actuated oil-replenishing system, has a working life in excess of 40,000 hours.
- The diaphragm is held independently of the pump head, so that when the head is dismantled, the diaphragm is retained in the body and no oil is lost. This significantly improves the ease of maintenance.
- The inclusion of an integral safety valve results in some 50% cost saving on the installation.
- Excellent value for the money is achieved thanks to the few components mechanism, such as the direct plunger stroke adjustment and the cam mechanism.

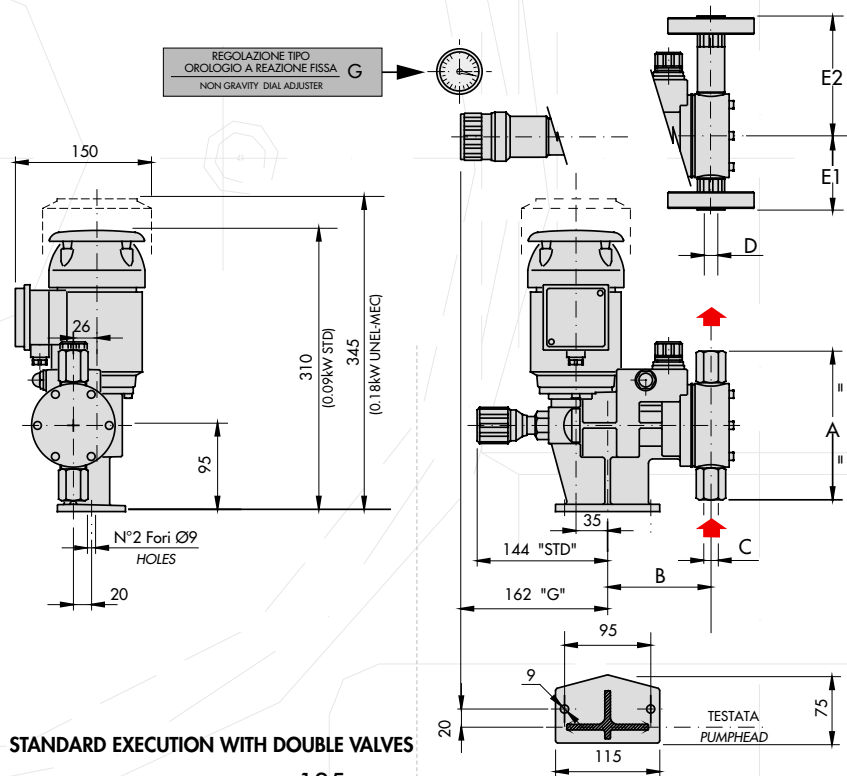

STANDARD EXECUTION WITH DOUBLE VALVES

① WITH SINGLEPHASE MOTOR = 135

TYPE	AISI 316 L					PVC - PVDF - PTFE					"HV" (AISI 316L)					D	
	A	B	C g.f.	E1	E2	A	B	Cg.f.	E1	E2	A	B	Cg.f.	E1	E2	UNI	ANSI
XR2. 15	164	108	1/4" g.f. BSPF	82	132	171	121	1/4" g.f. BSPF	85,5	135,5	-	-	-	-	-	-	-
XR2. 30	164	108	1/4" g.f. BSPF	82	132	171	121	1/4" g.f. BSPF	85,5	135,5	-	-	-	-	-	-	-
XR6. 30	164	108	3/8" g.f. BSPF	82	132	171	121	3/8" g.f. BSPF	85,5	135,5	162	114	1/2" g.f. BSPF	83	132	(AISI) UNS-F40	(ANSI) F40
XR6. 38	184	121	3/8" g.f. BSPF	92	142	182	134	3/8" g.f. BSPF	91	141	172	125	1/2" g.f. BSPF	86	137	(AISI) UNS-F40	(ANSI) F40
XR6. 48	184	121	3/8" g.f. BSPF	92	142	182	134	3/8" g.f. BSPF	91	141	172	125	1/2" g.f. BSPF	88	137	(AISI) UNS-F40	(ANSI) F40



BASIC MODELS

XR 2.30 P 85

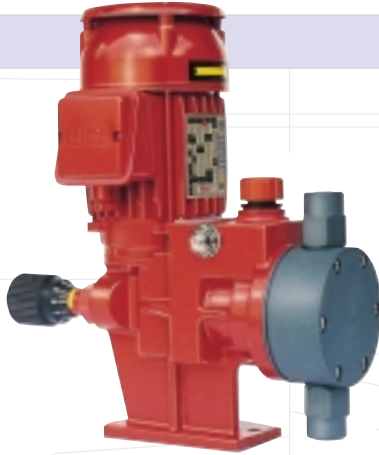

- PVC pump head
- "LAFERT" 3-phase motor
- Threaded connections
- Max. flow rate 5,5 l/h
- Max. pressure 10 bar

ADJUSTMENT SYSTEMS

- **Manual:** With 0-10 scale micrometer knob.
- **Electric:** Via **OBL** designed **Z** type 4÷20 mA electrical actuator.
- **Pneumatic:** Via of a 3÷15 PSI. type **W**. pneumatic actuator.

XR 6.30 A 85

- AISI 316L pump head
- "LAFERT" 3-phase motor
- Threaded connections
- Max. flow rate 17 l/h
- Max. pressure 20 bar



STANDARD MANUAL ADJUSTMENT



- 0÷100% adjustment by means of a micrometer knob.

XR 2.30 P 85 F MU

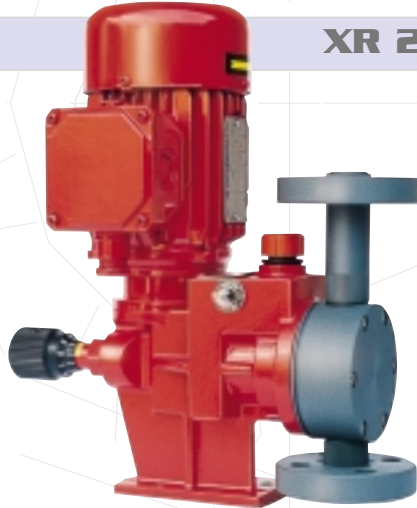

- PVC pump head
- 3-phase motor
- Flanged connections
- Max. flow rate 5,5 l/h
- Max. pressure 10 bar

MANUAL ADJUSTMENT ON DEMAND



- Flow rate adjustment is smooth and linear, and can be made whether the pump is running or stationary.

The non-gravity dial adjuster has a 0÷100% scale and will not lose the datum if turned over during transport.

XR 6.30 A 85 F MU G

- AISI 316L pump head
- 3-phase motor
- Flanged connections
- Max. flow rate 17 l/h
- Max. pressure 20 bar
- Non-gravity dial adjuster

