

Stroke: 11/17mm
 Max flow rate: 400 L/h
 Motors: 0,18 - 0,37 - 0,75 kW



**Plunger
 Metering Pump
 Positive Return**

API 675

*Model LY is the smallest of the four sizes in the "L" range; LY-LK-LN-LP.
 The pump is very compact, but has all the technical features of the positive displacement.
 The stroke adjustment is based on OBL's unique design.*

CONSTRUCTION CHARACTERISTICS

- OBL's metering pumps are used in several industrial plants. The "L" series ranges from the smallest capacity, 400 cc/h, to the largest, 11.000 L/h.
- All models can be built as multiple units with different sized heads.
- Each pumphead can have a different stroke rate since each has its own reduction gear.
- Power transmission through multiple units is easily achieved by a common motor-speed shaft, so the torque is lower than after the reduction gears.
- Positive displacement mechanism with mechanical return of the plunger, based on OBL's unique design.
- Smooth flowrate adjustment by control knob, either with pump in motion or stationary.
- 1% repeatability of flowrate within 10% and 100% of maximum capacity.
- Low NPSH requirement: as low as 1,5m in recommended installation conditions.

TECHNICAL DATA

TYPE	STROKES/m	FLOW RATE L/h	MAX PRESS.BAR				CONNECTIONS		
			0,18 kW		0,37 kW		THREADED	FLANGED	
			AISI 316L	PVC	AISI 316L	PVC		UNI	ANSI
LY6	50	1,2	40	-	100	10	3/8" G.F./Rp	15	1/2"
	70	1,8							
	95	2,3							
LY8	36	1,5	40	10	100	10	3/8" G.F./Rp	15	1/2"
	50	1,8							
	70	2,5							
LY10	50	3,5	40	10	100	10	3/8" G.F./Rp	15	1/2"
	70	4,5							
	95	6,5							
LY15	50	8	40	10	100	10	3/8" G.F./Rp	15	1/2"
	70	11							
	95	15							
LY20	50	14,5	23	10	70	10	3/8" G.F./Rp	15	1/2"
	70	20			60				
	95	28			50				
LY25	50	23	15	10	40	10	3/8" G.F./Rp	15	1/2"
	70	32							
	95	43							
LY30	50	32	-	-	40	10	3/8" G.F./Rp	15	1/2"
	70	45			40				
	95	62			33				
LY40	50	60	-	-	22	10	1/2" G.F./Rp	15	1/2"
	70	82			20				
	95	110			18				
LY50	50	90	-	-	14	10	-	20	3/4"
	70	130			13				
	95	175			11				
LY65	50	155	-	-	7	7	-	20	3/4"
	70	220							
	95	300							
LY75	50	210	-	-	4	-	-	25	1"
	70	300							
	95	400							

PUMP HEADS

The standard construction, up to 130 L/h, has duplex ball valves; higher flowrates have single valves.

- Materials of construction for wetted parts are:

- **Construction A:** AISI 316L
- **Construction P:** PVC-Ceramic - PTFE

Pumps in other materials such as Hastelloy, other alloys, PVDF etc., can be supplied on demand.

- Plunger packing is of reinforced Teflon chevron rings.
- Suction and discharge connections can be threaded or flanged, up to 130 L/h. For higher flowrates, flanged only.

- **Max. temperature of handled liquid:**
 - with standard stainless steel heads: 90 °C
 - with special stainless steel heads: 160 °C
 - with stainless steel heads and ceramic plunger: 90 °C
 - with PVC head: 40 °C
 - with PVDF head: 70 °C

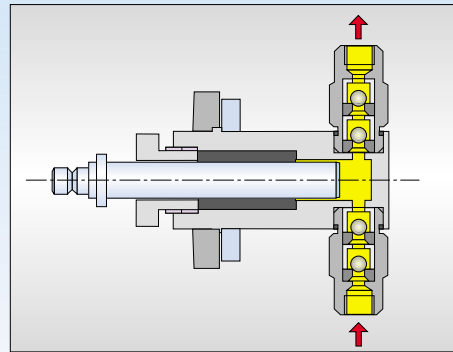

Inox steel head, "A" execution, with threaded connections.

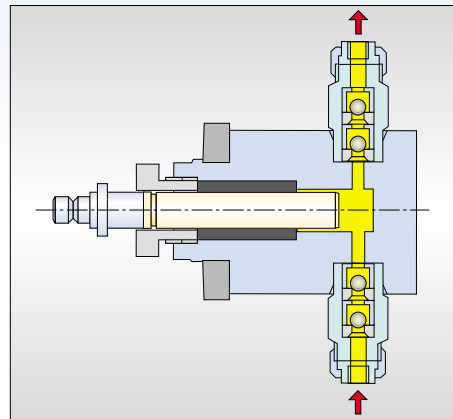

PVC head, "P" execution, with threaded connections.

OVERALL DIMENSIONS

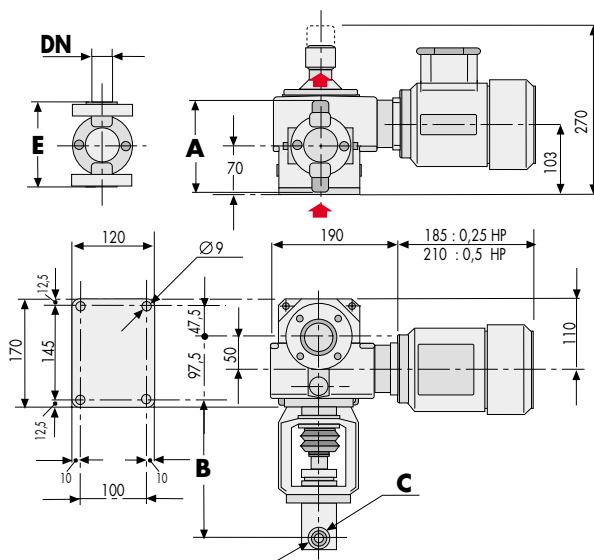

MODEL NUMBER

KEY TO SYMBOLS	
PUMP TYPE	
Ø PLUNGER	
A	AISI-316L VERSION
P	PVC VERSION
STROKES PER MINUTE	
Z...	ELECTRIC ACTUATOR 4÷20 mA
W	3÷15 PSI PNEUMATIC ACTUATOR
F	UNI-DIN FLANGED CONNECTIONS
FA	ANSI FLANGED CONNECTIONS
...	= 0 ÷ 10 BAR VERSION (NO NEED OF MODEL NO.)
TL	= 10 ÷ 40 BAR
TN	= 40 ÷ 100 BAR

LY 30 A 70 TL FA Z...

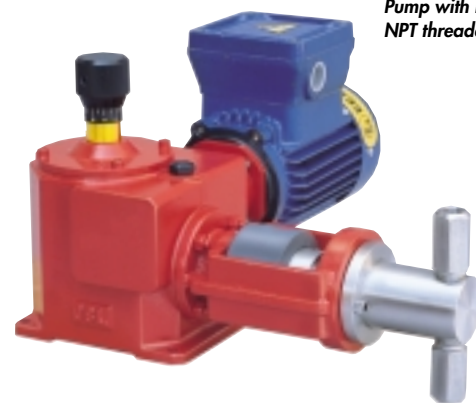

Pump with EExd motor and NPT threaded connections.

TYPE	AISI 316L					PVC					DN UN222/29		ANSI 316.5		HV AISI 316L			
	Adv	B	BTL	C	E	Edv	Adv	B	C	E	Edv	AISI PN40	PVC PN10	AISI 150RF	PVC 150RF	E	DN	ASA
LY 6-8	143	-	205		-	119	198	202		-	162	15	15	1/2"	1/2"	-	-	-
LY 10	143	-	205		-	119	198	202		-	162	15	15	1/2"	1/2"	-	-	-
LY 15	143	-	205	G.F.	-	119	216	202		-	162	15	15	1/2"	1/2"	124	15	1/2"
LY 20	143	210	225		-	119	216	200		-	162	15	15	1/2"	1/2"	124	15	1/2"
LY 25	143	210	225		-	119	216	200		-	162	15	15	1/2"	1/2"	124	15	1/2"
LY 30	159	210	225		-	119	230	200		-	176	15	15	1/2"	1/2"	156	20	3/4"
LY 40	195	210	-	1/2"	-	163	242	200	1/2"	-	204	15	15	1/2"	1/2"	156	20	3/4"
LY 50	-	210	-	-	157	213	-	205	-	224	268	20	20	3/4"	3/4"	180	25	1"
LY 65	-	210	-	-	187	256	-	205	-	224	268	20	20	3/4"	3/4"	-	-	-
LY 75	-	210	-	-	200	-	-	-	-	-	-	25	-	1"	-	-	-	-

MATERIALS OF CONSTRUCTION

PARTS	A	P	AC	ACV	H
LIQUID END	AISI 316L	PVC	AISI 316L	AISI 316L	AISI 316L
PLUNGER	AISI 316L	CERAMIC	CERAMIC	CERAMIC	CERAMIC
PACKING	TEFLON/PTFE	TEFLON/PTFE	TEFLON/PTFE	VULKOLLAN POLYURETHAN	TEFLON/PTFE
VALVE SEAT	AISI 316L	PVC	AISI 316L	AISI 316L	INCOLOY 825
VALVE	AISI 316L	PIREX	AISI 316L	AISI 316L	CARPENTER 20
VALVE SEAL	VITON/FPM	VITON/FPM	VITON/FPM	VITON/FPM	VITON/FPM