

LY X9 Technical data

TYPE	FLOW RATE l/h	MAX PRESS. BAR	CONNECTIONS		kW
			THREADED	FLANGED	
LY10	1,5	100	1/4" NPT F	1/2" ANSI	0,37
LY10	8	100	1/4" NPT F	1/2" ANSI	0,37
LY15	3	100	1/4" NPT F	1/2" ANSI	0,37
LY15	23	100	1/4" NPT F	1/2" ANSI	0,37
LY20	10	70	3/8" NPT F	1/2" ANSI	0,37
LY20	33	70	3/8" NPT F	1/2" ANSI	0,37
LY25	15	60	3/8" NPT F	1/2" ANSI	0,37
LY25	50	40	3/8" NPT F	1/2" ANSI	0,37
LY30	25	40	3/8" NPT F	1/2" ANSI	0,37
LY30	100	30	3/8" NPT F	1/2" ANSI	0,37

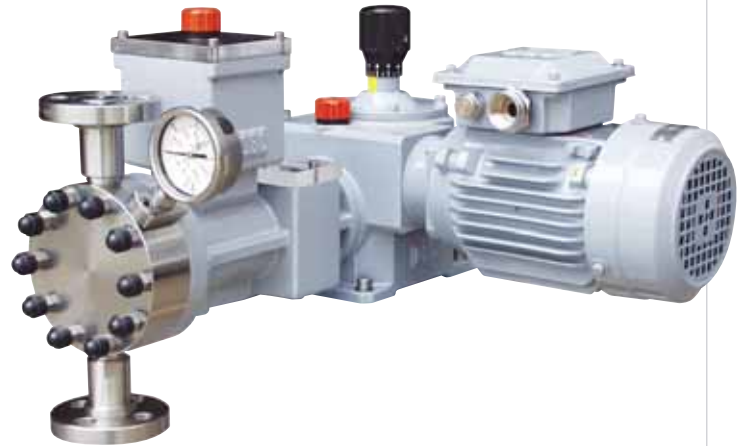

LY X9A series process diaphragm metering pump with AISI 316L pump head.



- Flow rates: • Max flow rate 100 L/h
- Motors: • kW 0,18 - kW 0,37
- Pump: • Single and multiple
- Adjustment: • Manual and automatic
- Casing material: • Cast iron
- Stroke: • 17 mm.
- Strokes/1': • 36-50-70-95-100-118
- App. Weighth: • 30÷60 Kgs

MATERIALS OF CONSTRUCTIONS

PARTS	X9 A		X9 P	
	LY 10-15	LY 20-25-30	LY 10-15	LY 20-25-30
LIQUID END	AISI 316L	AISI 316L	PVC	PVC
VALVE	CERAMIC	AISI 316L	CERAMIC	PIREX
VALVE SEAT	CERAMIC	AISI 316L	CERAMIC	PVC
VALVE GUIDE	AISI 316L	AISI 316L	PVC	PVC
VALVE SEAL	FPM	FPM	FPM	FPM
DIAPHRAGM	PTFE	PTFE	PTFE	PTFE

MAX OVERALL DIMENSIONS

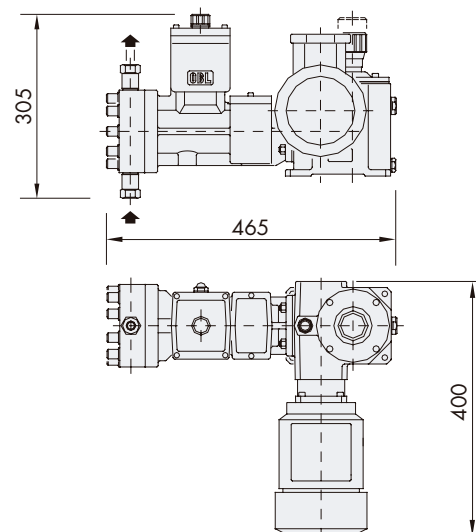

KEY TO MODEL NUMBER

LY	PUMP TYPE
30	PLUNGER Ø
X9A	SS316L VERSION
X9P	PVC VERSION
X9S	PVDF VERSION
X9T	PTFE VERSION
70	STROKES PER MINUTE
Z	ELECTRIC ACTUATOR
W	PNEUMATIC ACTUATOR
FA	ANSI FLANGED CONNECTIONS
F	DIN FLANGED CONNECTIONS

Example model number: LY 30 X9A 70 FA Z