

# LN X9 Technical data

TYPE	FLOW RATE l/h	MAX PRESS. BAR		FLANGED CONNECTIONS	kW
		X9	X9TS		
LN25	60	100	140	3/4" ANSI	1,5-2,2
LN25	155	80	100	3/4" ANSI	1,5
LN30	112	90	-	3/4" ANSI	1,5
LN30	240	65	-	3/4" ANSI	1,5
LN65	500	22	-	1 1/2" ANSI	1,5
LN65	1050	16	-	1 1/2" ANSI	1,5
LN80	900	15	-	1 1/2" ANSI	1,5
LN80	1620	8	-	1 1/2" ANSI	1,5
LN100	1500	8	-	1 1/2" ANSI	1,5
LN100	2500	5	-	2" ANSI	1,5



LN X9A series process diaphragm metering pump with AISI 316L pump head.

# LN 2500 l/h

- Flow rates: • Max flow rate 2500 L/h
- Motors: • kW 0,75 - kW 1,5
- Pump: • Single and multiple
- Adjustment: • Manual and automatic
- Casing material: • Cast iron
- Stroke: • 50 mm.
- Strokes/1': • 68-80-96-120
- App. Weigth: • 150 Kgs

## MATERIALS OF CONSTRUCTIONS

PARTS	X9 A	X9 P
LIQUID END	AISI 316L	PVC
VALVE	AISI 316L	PIREX
VALVE SEAT	AISI 316L	PVC
VALVE GUIDE	AISI 316L	PVC
VALVE SEAL	FPM	FPM
DIAPHRAGM	PTFE	PTFE

## MAX OVERALL DIMENSIONS

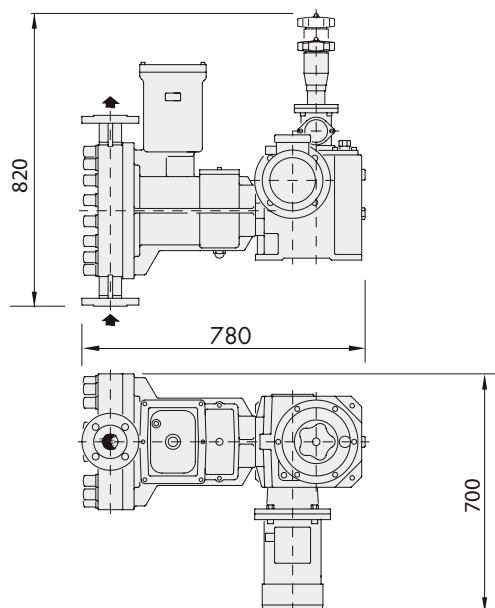

## KEY TO MODEL NUMBER

LN	PUMP TYPE
100	PLUNGER Ø
X9A	SS316L VERSION
X9P	PVC VERSION
X9S	PVDF VERSION
X9T	PTFE VERSION
96	STROKES PER MINUTE
Z	ELECTRIC ACTUATOR
W	PNEUMATIC ACTUATOR
FA	ANSI FLANGED CONNECTIONS
-	DIN FLANGED CONNECTIONS

**LN 100 X9A 96 FA Z**