

LK X9 Technical data

TYPE	FLOW RATE l/h	MAX PRESS. BAR	CONNECTIONS	kW
LK30	45	70	3/4" ANSI	0,75
LK30	105	52	3/4" ANSI	0,75
LK40	80	40	3/4" ANSI	0,75
LK40	200	28	3/4" ANSI	0,75
LK50	135	25	1" ANSI	0,75
LK50	320	18	1" ANSI	0,75
LK65	230	15	1" ANSI	0,75
LK65	550	11	1" ANSI	0,75
LK80	520	10	1 1/4" ANSI	0,75
LK80	1050	5,5	1 1/4" ANSI	0,75

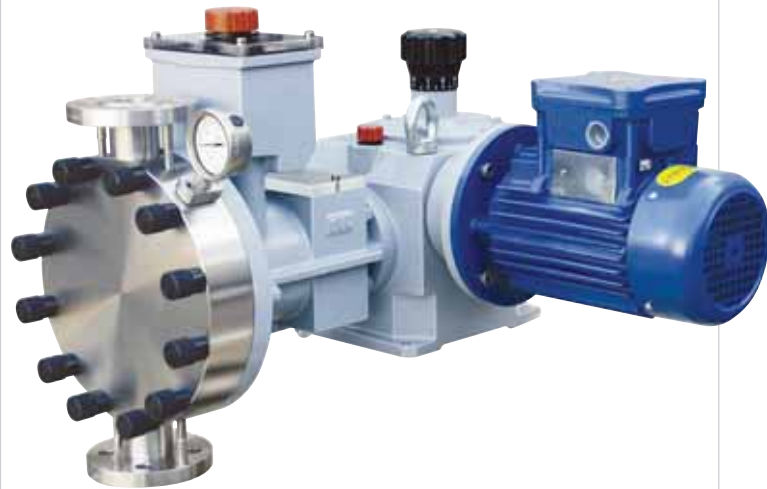

LK X9A series process diaphragm metering pump with AISI 316L pump head.

LK 1050 l/h

- Flow rates: • Max flow rate 1050 L/h
- Motors: • kW 0,37 - kW 0,75
- Pump: • Single and multiple
- Adjustment: • Manual and automatic
- Casing material: • Cast iron
- Stroke: • 30 mm.
- Strokes/1': • 42-60-82-100
- App. Weigth: • 40÷70 Kgs

MATERIALS OF CONSTRUCTIONS

PARTS	X9 A	X9 P
LIQUID END	AISI 316L	PVC
VALVE	AISI 316L	PIREX
VALVE SEAT	AISI 316L	PVC
VALVE GUIDE	AISI 316L	PVC
VALVE SEAL	FPM	FPM
DIAPHRAGM	PTFE	PTFE

MAX OVERALL DIMENSIONS

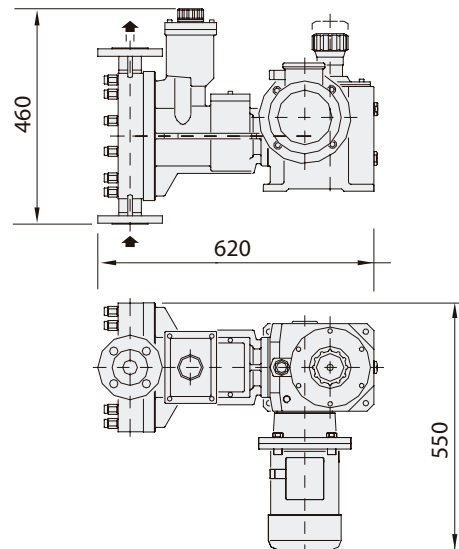

KEY TO MODEL NUMBER

LK	80	X9P	82	FA	Z	LK	PUMP TYPE
						80	PLUNGER Ø
						X9A	SS316L VERSION
						X9P	PVC VERSION
						X9S	PVDF VERSION
						X9T	PTFE VERSION
						82	STROKES PER MINUTE
						Z	ELECTRIC ACTUATOR
						W	PNEUMATIC ACTUATOR
						FA	ANSI FLANGED CONNECTIONS
						-	DIN FLANGED CONNECTIONS